



4-Port BRI-Hub (UK):
ISU2011-4-UK

4-Port BRI-Hub (Euro):
ISU2011-4-EURO

8-Port BRI-Hub (UK):
ISU2011-8-UK

8-Port BRI-Hub (Euro):
ISU2011-8-EURO

BRI-Hub



TECHNICAL: (0118) 965 6000

SALES: (0118) 965 5100

FAX: (0118) 965 5001

ADDRESS: 464 Basingstoke Road, Reading, Berkshire RG2 0QN

WEB: www.blackbox.co.uk

How To Contact your Local Black Box

Italy:

Black Box Italia S.P.A
Tel: 0227400280
Fax: 0227400219
Web Site: www.blackbox.it

Australia:

Black Box Catalog Australia PTY LTD
Tel: 0398797100
Fax: 0398702955

Deutschland:

Black Box Deutschland
Tel: 0811/5541-0
Fax: 0811/5541-499
Web Site: www.blackbox-deutschland.com

Brazil:

Black Box Do Brasil.
Tel: (011) 5515-4000
Fax: (011) 5515-4002
Web Site: www.blackbox.com.br

Switzerland:

Datacom Black Box Services AG
Tel: 0554517070
Fax: 0554517075
Web Site: www.black-box.ch

Canada:

Black Box Canada Corp.
Tel: 0416-736-8000
Fax: 0416-736-7348
Web Site: www.blackbox.com

Netherlands:

Black Box Datacom BV
Tel: 03032417799
Fax: 0302414746
Web Site: www.blackbox.nl/

Mexico:

Black Box De Mexico S.A. de C.V
Tel: 05-420-0100
Fax: 05-420-0123
Web Site: www.blackbox.com.mx

Belgium:

Black Box
Tel: 027258550
Fax: 027259212
Web Site: www.blackbox.be

Japan:

Black Box Catalog
Tel: 03-3820-5011
Fax: 03-3820-5010
Web Site: www.blackbox.co.jp/

France:

Black Box Catalogue
Tel: 0145606700
Fax: 0145606747
Web Site: www.blackbox.fr

U.S.A

Black Box Corporation
Tel: 724-746-5500
Fax: 724-746-0746
Web Site: www.blackbox.com

Spain:

Black Box Comunicaciones S.A.
Tel: 34 91 663 0200
Fax: 34 91 661 84 35
Web Site: www.blackbox.es

Chile

Black Box Chile
Tel: 00 562 223 8811
Fax: 00 562 225 1002
Web Site: www.Blackbox.cl



Contents

Introduction	4
Description of functions	4
Options	5
BRI-Hub	5
BRI-Hub S.....	5
Technical Specifications	6
SO Interface BRI.....	6
Common Features	6
Power supply	6
Power Supply	7
Sound Emission.....	7
S ₀ -Interface	6
Parts List.....	7
Installation.....	8
Tabletop.....	8
Wall mount.....	8
Rack Mount.....	8
Power Supply	9
BRI-Hub	9
BRI-Hub-S	9
Connecting the Hub.....	10
Power Failure Operation	11
Termination Resistors	13
Operation.....	14
Displays and Controls	14
Displays	14
Controls	14
Maintenance	14
Cleaning	14
Troubleshooting	15



Introduction

Within the data communications and LAN industry it is well known that a structured cabling concept using a star topology has significant advantages, such as easier maintenance, unproblematic changes in the configuration and faster fault finding. Last but not least, a structured cabling concept may be used for all kinds of LAN-, WAN and telecommunications technologies.

Nevertheless, with ISDN a bus has to be formed to connect several users to one Basic Rate Interface (BRI), but a bus cannot be formed with a star topology. Alternatively a complete BRI must be dedicated to one user (point to point configuration), which is in many cases not feasible or too expensive.

By using the active star BRI-Hub it is now possible to use the structured star-cabling concept for ISDN. In addition the distance between the NT and the TEs may be extended because of the use of point-to-point links between the BRI-Hub and the TEs. It is also possible to use the "extended passive bus configuration" (distance up to 1000m) if all connections to the TEs are in the same range of distance (+/- 50m).

The Phantom Feed unit can be used with the BRI-Hub to provide power to all 4 or 8 ports on the BRI-Hub.

Description of functions

The BRI-Hub converts the ISDN BRI bus structure to a set of point-to-point connections, which are connected within the BRI-Hub to form a 'logical bus'. At this, the BRI-Hub makes it possible to hook up ISDN terminals via a maximum of 8 lines with the maximum length of 150 m each. Up to 1000 m is possible in a special configuration. Every port forms a separate electrical segment. Through this wiring faults don't affect other segments.

Old, bus configuration

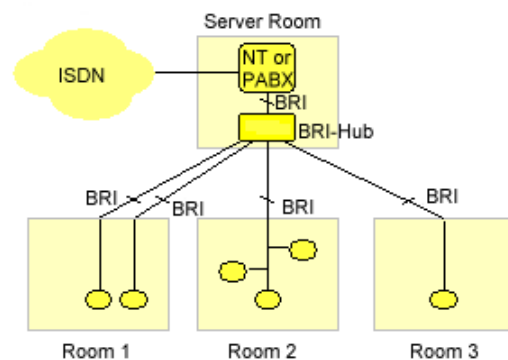
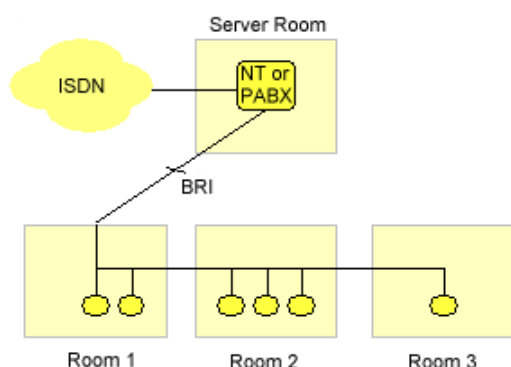

BRI-Hub Configuration



If a BRI needs to be made available in several rooms, it used to be necessary to install a bus from the server room through all rooms. (See picture 'old'). Now star wiring can be used with BRI-Hub, which comes to use also for telephone and local area networks (see picture 'with BRI-Hub').

Options

BRI-Hub

This option derives its power from the power supply provided.

BRI-Hub S

This option derives power from the S-Bus and uses an internal DC-DC converter to adapt the voltage to power itself – no external power supply is required. This option is available as a special request from Black Box.

Both of the above options can be used in conjunction with the Phantom Feed, a device used to provide power on each of the hub's S interfaces.



Technical Specifications

SO Interface BRI

Number of interfaces.....	5 for BRI-Hub-4, 9 for BRI-Hub -8
Type and coding.....	I.430, Mod. AMI, 4-wire
Frame structure.....	I.430 (48 Bits per 250 μ s)
Transmission rate.....	192 kbps +/- 50 ppm
Interface connector.....	RJ-45

Common Features

Size (W x H x D).....	205 x 40 x 110 mm
Weight.....	450g
Housing material.....	ABS
Protection class.....	IP 21
Environmental temperature.....	0° to 40° C
Storage temperature.....	-20° to 70° C
Humidity.....	max. 90% (non condens.)
Supply voltage.....	6 - 9V
Power consumption.....	max. 2W

Power supply

Primary voltage.....	220V~ +/-10%, 50 Hz
Output voltage.....	6V=
Output current.....	max. 500mA

S0-Interface

Connector: RJ-45 (ISO 8877, EN 28877)

Pin	Signal	Direction	Power Feeding
1			PS3 +
2			PS3 -
3	TE(+)	TE → NT	PS1 + (Phantom)
4	NT(+)	NT → TE	PS1 - (Phantom)
5	NT(-)	NT → TE	PS1 - (Phantom)
6	TE(-)	TE → NT	PS1 + (Phantom)
7			PS2 -
8			PS2 +



Environmental and Safety Notes

The device conforms to all european and international standards for safety, environment, EMC and the ISDN basic rate interface.

Power Supply

- The power adaptor is according to safety class II (VDE 0551) and my only be used indoor.
- Do not use the power adaptor when it was brought from a cold to a warm environment. In that case condensing water may damage the unit.
- There are no user serviceable part inside the power adaptor. Therefore it is not necessary to open the unit

Sound Emission

The unit does not emit any sound.

Parts List

When opening your BRI-Hub the following parts should be present:

- BRI-Hub unit
- ISDN cable with two RJ45 plugs (Western plugs) to connect the BRI-Hub to the network termination (NT) or the PABX basic rate interface. The cable has a length of 2m.
- Power Supply adaptor (not with BRI-Hub-S)
- Users Manual
- Two 6mm dowels and two 6mm screws for wall mounting

The power feeding unit, The Phantom Feed, may be used to feed all TE ports with power (40V, 8W). This device is available as an option.



Installation

For proper operation the device must be placed in a suitable location. It should be a clean and dry environment without direct sun light. Sufficient cooling must be possible. Do not pack or cover the unit or set other warm equipment on top of it.

Tabletop

Just place the unit on a clean and dry place. Multiple BRI-Hub units may be stacked. The rubber stands give enough space for proper cooling.

Wall mount

The wall assembly works as follows:

- Drill two holes vertically, one above the other with a separation of 95 mm, into the wall where you want to place the BRI-Hub.
- Completely put the dowels into the drilled holes.
- Turn the BRI-Hub screws into the dowels; with a separation of approx. 7 mm still left between wall and screw head.
- Now place the BRI-Hub so that the screws fit into the holes in the floor plate. The power LED is in the upper right corner.
- Carefully shift the BRI-Hub downward, so that the screws move into the slots inside the floor plate.

Caution! Don't use any excessive force. If the screws are turned too far into the dowels, the screws may not move into the slots. Turn the screws out a little and try again.

Rack Mount

For the assembly into a rack an optional 19" front panel is needed. This may hold one or two BRI-Hub devices. This 19" rackmount panel is available as a special from Black Box. Please call technical support for further information. The front panel is fixed to the BRI-Hub devices by two engine screws.

- To do this the panel is set onto the front of the BRI-Hub.
- The two screws are put into the holes of the panel provided for this. (Left from the NT port and right besides the power LED).



- The screws must be put into the holes of the BRI-Hub. The screws slide approximately 25 mm into the case.
- The screws can be screwed in tight.

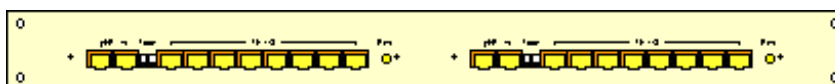

Power Supply

BRI-Hub

The standard BRI-Hub is supplied with a wall mount power adaptor. There is no power switch at the device. The BRI-Hub is active when the power adaptor is plugged into an outlet and the DC connector of the power adaptor is connected to the BRI-Hub.

BRI-Hub-S

Besides the operation with a power adaptor it is possible for a BRI-Hub-8S or BRI-Hub-4S to get its power through the power feeding of the NT or PABX via the NT port. Please note that the BRI-Hub needs approximately twice the power as an ISDN telephone. Therefore it is not possible to operate the BRI-Hub from the 'restricted mode' power feeding.

If the DC connector of the power adaptor is plugged into the BRI-Hub DC socket, the BRI-Hub will switch to the power adaptor automatically even if the power supply doesn't deliver any electrical power. Therefore it is necessary to unplug the DC connector from the BRI-Hub when the power feeding of the BRI is used.



Connecting the Hub

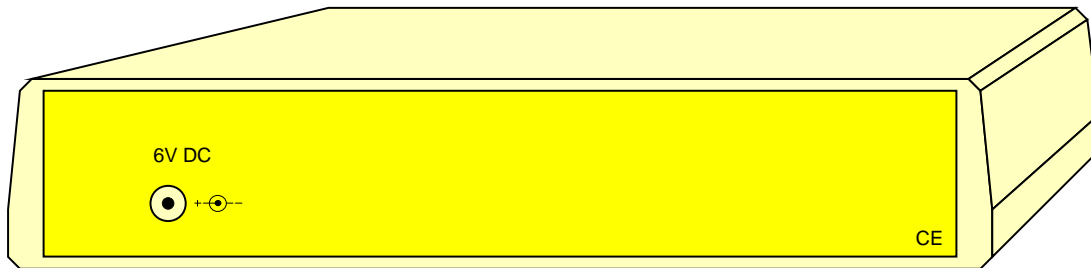

The DC connector of the power adapter is inserted into the jack on the left side of the rear panel (Jack "6V DC").

Do not use other power adaptors than the original one. In any case notice the polarity of the connector. Inner tip +, outer ring -.

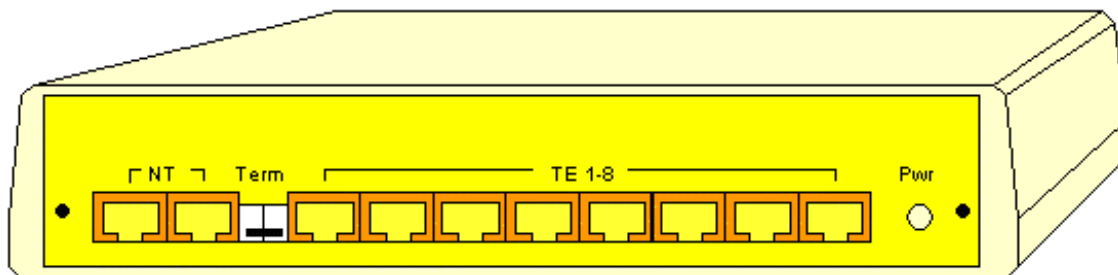

To connect the BRI-Hub to the NT or an internal BRI of a PABX, use one of the connectors labelled 'NT'. Use the enclosed ISDN-cable. Both connectors are parallel connected, so it doesn't matter which one you chose. The second connector may be used to connect a test device or other TEs. (see 'Power Failure Operation' on next the page).

Termination of the NT-port may be switched on and off using the Term-switch. When installing the BRI-Hub, check that both ends of the bus are terminated properly, but only the ends!

Depending on the quality of your cables, a maximum length of 150m may be connected to every TE-port of the BRI-Hub. Note that the sum of the cable lengths (NT-BRI-Hub plus BRI-Hub-TE) should not exceed 150m. Since the BRI-Hub will normally be placed directly next to the NT or the PABX, the entire 150m are available for the TE connection.



The TE-ports termination resistors are permanently active and cannot be switched off.

Please install terminating resistors to the end of the connecting cables.

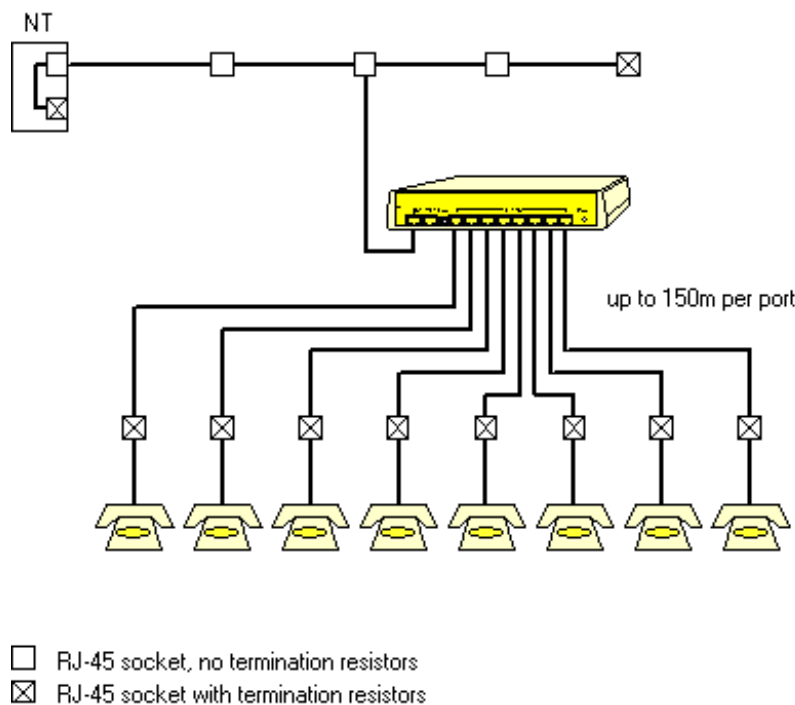

In the above example the Term-switch must be in the off position, i.e. termination resistors are off. This is because the BRI-Hub is not connected to the end of the bus.

Power Failure Operation

If the BRI-Hub loses power, the terminal devices directly connected to the NT ports will still operate. For this to happen case one must observe the maximum cable length and the position of the terminating resistors. In more detail this is:

- The length of the cable connecting the NT to the BRI-Hub plus the length of the cable connecting the BRI-Hub to the TE on the second NT port must not be longer than 150m. Both cables form a passive bus.
- In case of a bus installation at the NT port, BRI-Hub must be the last device on the bus.
- The termination resistors must be switched off. Termination resistors must be installed at the end of the TE's bus



Configuration for power fail communication with the BRI-Hub

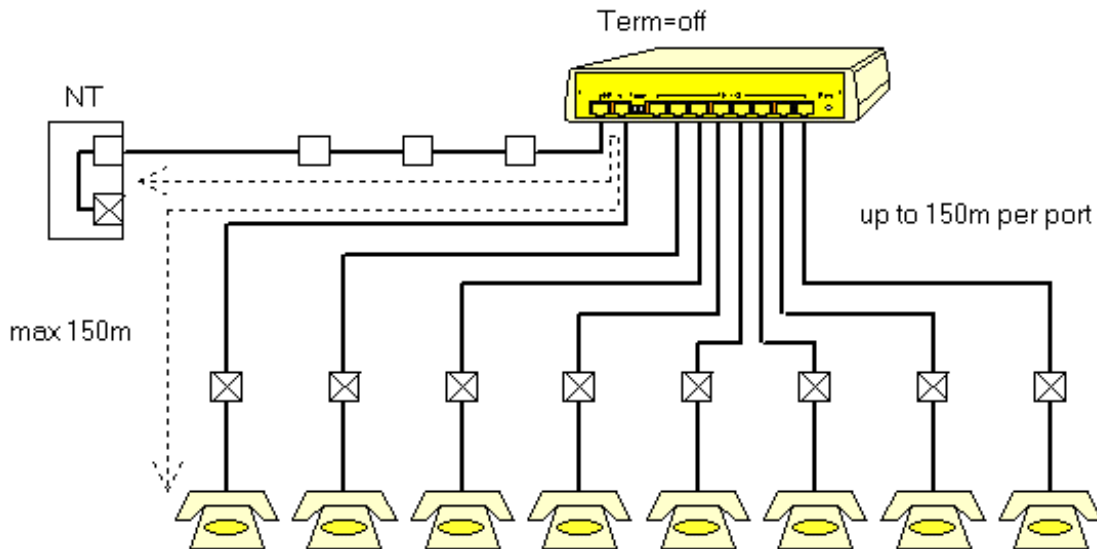

Note:

- RJ-45 socket, no termination resistors
- RJ-45 socket, with termination resistors

If cable connections between the BRI-Hub and the terminal equipment (TE) are longer than the proposed 150m, operation may be possible under specific conditions:

1. The NT must be switched to "extended passive bus". "Point-to-point" or "adaptive timing".
2. All cable connections at the TE ports must have the same range of length, i.e. +/- 50 to 100m, depending on the cable quality.



Termination Resistors

The signal pairs must be terminated with 100Ω resistors at both ends of the bus.

These must be installed as shown below. If not placed correctly, they may short the power feeding voltage.

Pin	Pin description	Direction
1		
2		
3	2a	TE → NT
4	1a	NT → TE
5	1b	NT → TE
6	2b	TE → NT
7		
8		

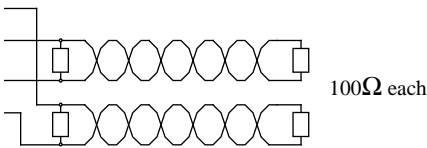

Operation

No service is needed during operation.

Cable shorts at one TE port only affect the power feeding voltage of all ports if they are internally connected. To reduce this effect self-healing fuses are connected to each port.

The current version of the BRI-Hub cannot clear problems with cable reversals of the TE pair (Pins 3 and 6 of the RJ-45). If one of the connected TEs has such a pair reversal, no operation is possible since the pulses sent by different TEs have different polarity.

Displays and Controls

Displays

Pwr is on (green), when the BRI-Hub is operating. I.e. the power supply is active. This may be the power adaptor or the power feeding when using the 'S' option (BRI-Hub-S)

Controls

Term **On:** (down position). Both pairs of the NT port are terminated (100Ω).
Off: (up position). Termination resistors off.

Maintenance

Cleaning

To clean the BRI-Hub use a damp piece of cloth or antistatic cloth. Please do not use scoring or alcoholic fluids.

Caution! Never clean the BRI-Hub wet. This may cause short circuits inside the device.



Troubleshooting

Fault	Problem	How to clear the problem
Pwr-LED is off	BRI-Hub is powered off	Plug in power adaptor
	No mains power	Check for main power
	Faulty power adaptor	Use other compatible power adaptor. Check polarity!
	For BRI-HUB-S only: loss of power inside NT or PABX	Use original power adapter
	BRI-Hub is faulty	Please return the device to your dealer.
Specific devices on a port do not operate via the BRI	Cable shorts	Use another port for test. Check for cabling faults.
	Faulty terminal equipment	Check with other equipment
	Cable too long	Connect TE directly to the BRI-Hub for test
Only devices at port 1 may communicate	A BRI-HUB is used which is in the power down mode	Power on the BRI-HUB

If you are still having problems with you BRI-Hub, please call Black Box technical Support.



Notes

